

Shore 100 Propping System

Hazard and Risk Assessments

Before using this equipment, the job you are doing must be assessed for foreseeable hazards and risks and appropriate measures to eliminate, control or reduce those risks must be taken before you commence work.

Suggested PPE (Personal Protective Equipment):

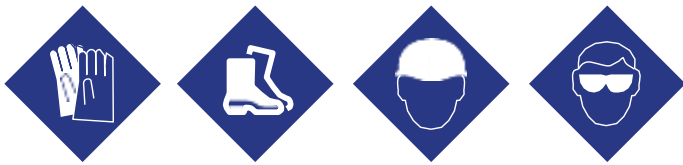

Protective Gloves Protective Footwear Hard Hat Eye Wear

Note: PPE must be suited to the risks and person(s) using the equipment.

Safety Instructions:

1. **Operating Instructions** – Before using this equipment ensure you have read the ‘Operating Instructions’ and taken note of the ‘Hazards and Risks’ detailed on this instruction sheet and taken all necessary steps to prevent injury.
 2. **Personal Protective Equipment** – Use appropriate personal protective equipment for the job.
 3. **Installation Advice** – The safe use and application of these props must be in accordance with AS3610, the Occupational Health and Safety Act, approved Codes of Practice and any other regulatory requirements. Consultation with a qualified engineer is advised.
- HAZARD: Risk of Structural Collapse and Crushing**
 ... Incorrectly installed or rated propping systems may cause structural collapse.
 ... Consultation with a qualified engineer is advised.
4. **Approved Components Only** – Only components and accessories that have been designed for use with Shore 100 propping systems and supplied by Shore Hire may be used. All nuts and bolts used must be Grade 8.8.
 5. **When Designing Applications** – Engineering drawings detailing the design of the structure, cross bracing and raking requirements, additional support of horizontal members etc. must be consulted. Failure to do so will lead to an increased risk of structural collapse and crushing.
 6. **Work Area**
 - i. During installation of propping system, ensure all bystanders are kept clear of work area.
 - ii. Installations that take place in close proximity to pedestrian or vehicle traffic should be barricaded to minimize risk of personal injury or property damage.
 7. **Avoid Body Strain**
 - i. If equipment is too heavy, ask for assistance when loading/unloading, positioning etc. or use mechanical device.
 - ii. Adopt recommended manual handling techniques e.g. keep a straight back when lifting and use your leg muscles to take the weight.

Installation Requirements:

The Shore 100 Propping System is HIGH RISK equipment. Installers must have sufficient training/instruction to properly install and use this equipment.

ENSURE YOU HAVE BEEN PROPERLY INSTRUCTED BEFORE USING THIS EQUIPMENT.

Purpose for which this equipment is designed:

For supporting formwork, concrete, ‘dead’ and ‘live’ loads when used as a back prop provided the propping system is installed correctly and its rated load is not exceeded. May also be used for creating stand-alone frames and raking struts.

8. **Look Up and Live** – Stay clear of overhead wires and other obstructions when positioning and installing propping systems. Refer to local regulatory authorities for minimum power line clearances.
9. **Rated Load**
 - i. Do not exceed the props working load limits. Refer to product ‘Technical Data Sheets’ (available from Shore Hire) for ‘Allowable Compression and Propping Loads’.
 - ii. When props are setup in non-vertical positions, the working load limits are reduced. Additional or higher rated props may be required.
10. **Install the Props Correctly**
 - i. Ensure props are installed on a firm level surface capable of supporting the load. Where the surface is not firm and level, steel or hardwood ‘sole plates’ should be used to spread the load and/or provide a level surface.
 - ii. When used in vertical applications, ensure prop sections are installed as close to vertically upright as possible. Props installed on an angle may slip, not be able to take the load, cause structural collapse and reduce load capacities.
11. **Avoid Lateral Movement**
 - i. Be aware of lateral (sideways) movement of the propping system when supporting uneven or ‘live’ loads, or being subject to a sideways force e.g. being hit by machinery on site etc. Where possible bolt/secure propping system in place.
 - ii. Where multiple propping structures are to be installed, ‘cross-brace’ the assembly to avoid lateral movement.
12. **Do Not Use to ‘Jack Up’ a Load or Structure** – Screw jacks to raise or lower the prop under the load. Do not hammer the prop into position.
13. **Adjust the Prop into the Load** – Use the screw jacks to raise or lower the prop under the load. Do not hammer the prop into position.
14. **Equipment Inspections** – Prior to use and at regular intervals whilst in use, the propping system components should be inspected by a suitably competent person to ensure they have not been damaged when transported, craned, installed or while in position under load on site.
 Any damaged equipment must be returned immediately to Shore Hire for inspection. Do not attempt to repair or modify any propping system equipment.

Installation Instructions:

Propping Sections:

Sections are joined together with a minimum of four (4) x Grade 8.8 M16 bolts, nuts and washers. They can be bolted end to end, and can also be bolted to the web of Shore 1000.

A variety of accessories can also be bolted to the propping sections.

Propping Section Assembly:

Bolt the propping sections together as follows:

- i. Align the holes in the end plate of section with the holes in the end plate, flange or web (using end connectors) of another section.
- ii. Insert an M16 bolt through each corner hole of the end plate, secure with nut and washer.
- iii. Using a 24mm spanner or similar, tighten each bolt until they are 'snug tight'.

Note: AS 4100 defines 'snug tight' as the tightness of a bolt achieved by a few impacts of an impact wrench or by the full effort of a person using a standard podger spanner.

- iv. Do not over tighten the bolts beyond 'snug tight' as doing so may damage or strip the threads preventing the components bolting together correctly.

Screw Jacks:

Screw jacks may be positioned either at the bottom or at both ends of the propping structure. **Do not install a screw jack between two propping sections. Screw jacks are right and left hand.**

Screw Jacks Assembly:

- i. Bolt the screw jacks to the propping sections as follows:
- ii. Align the holes in the screw jack base with the holes in the end plate on the propping section.
- iii. Insert an M16 bolt through each corner hole of end plate, secure with nut and washer.
- iv. Tighten each bolt until they are 'snug tight' - see note above.

Adjusting the Propping System Height:

When in position the propping structure can be raised or lowered to the load bearing height by rotating with the jack spanner.

Caution:

When extending the screw jack do not extend them beyond an overall maximum of 600mm that is their maximum capacity. Always use a Shore 100 jack spanner to adjust jack.

Do not use the screw jacks to raise or lower the load as this may lead to component damage and possible structure failure. Screw jacks have been designed for the adjustment of the propping system only and must only be used to position the propping system under/into the load.

End Detail

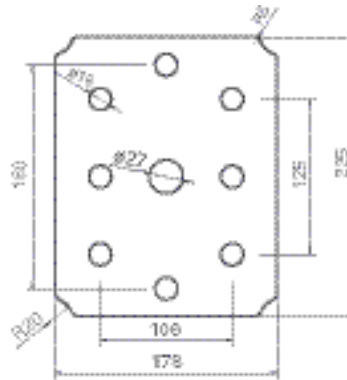

Section Detail

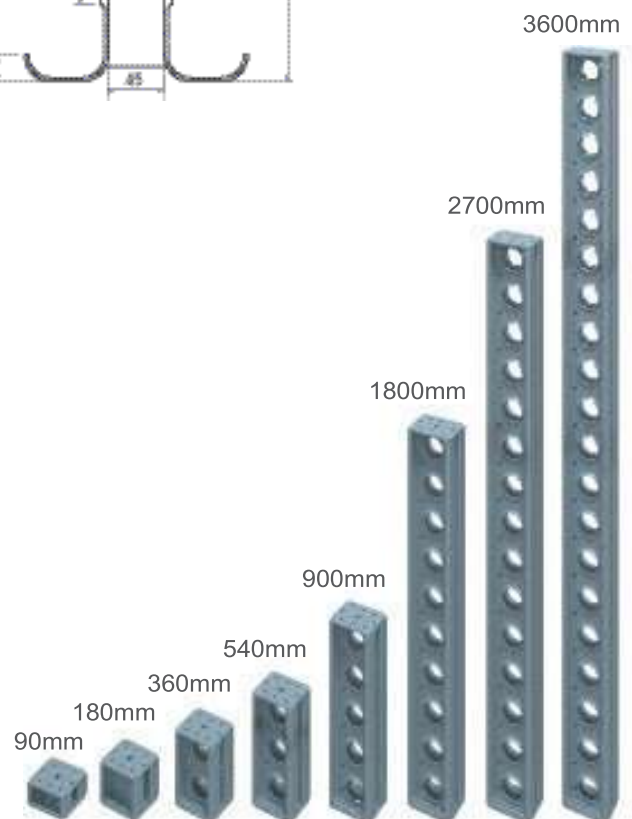
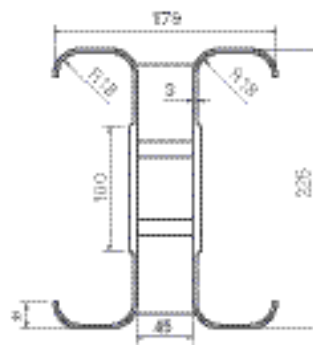

Installation Instructions Cont.:

Accessories:

A range of Shore 100 accessories are available, most are listed one to twelve on this page. Needle beam clamps and cross bracing are also available.

Advice When Using Needle Beams:

Needle beams should be secured to the propping structure with the purpose designed 'Beam Clamps'. DO NOT use the beam clamps for any other purpose.

Dismantling Instructions:

HAZARD Risk of Structural Collapse and Crushing

... Do not remove 'loaded' props.

Before removing props, ensure the load is self supporting (or supported by other means) and will not collapse when props are removed.

With the prop supported to ensure it will not fall over when removing from load, dismantle the prop as follows:

1. If prop previously secured in place, undo securing bolts, remove bracing etc.
2. Shorten the length of the prop approx. 50mm by rotating the base jack. Do not hammer the prop to remove.
3. Lay the prop on the ground.
4. To dismantle prop, undo all M16bolts.

Shore 100 Accessories



Description	Weight
1. Sixway Connector	25kg
2. Shore 1000 Strut Adaptor	4.5kg
3. Tilt Base	6kg
4. Shore 100 Strut Adaptor	4.2kg
5. Connecting Angle	2.2kg
6. Scaffold Bracket	2kg
7. End Plate Adaptor	1.6kg
8. Rocking Head	9.5kg
9. Foot Jack Adaptor	5.2kg
10. Jack Spanner	1.0kg
Shore 100 Jack	
11. - Left Hand=Gold, Right Hand=Silver	
- Jack Only (390-600mm)	12.8kg
- Jack with Foot Jack Adaptor (440-650mm)	18kg
12. Shore 400 - 100 Flange Connector	11kg

SCAN ME FOR TECH DATA



RISK ASSESSMENT (1= HIGH RISK, 5 = LOW RISK)

Risk (Ranking)	Description	Control
1	Erecting props on unstable/shifting foundation could cause a collapse seriously injuring personnel.	Always ensure base area is firm, clean and capable of supporting the load without shift or movement.
1	Overloading props creates a very high risk of collapse possibly causing, serious injury or death.	Strictly follow the engineers advice, do not overload props and always observe props 'load capacity'.
2	Loose or incorrect nuts, bolts or washers could cause prop failure.	Ensure all nuts, bolts or washers are tightened to correct torque and that the correct nuts, bolts or washers are used.
3	Cuts and grazes from improper handling procedures.	Observe safety procedures, always wear correct PPE.
2	Dropping units, trapping hands and feet, mishandling.	Follow safety procedures, use PPE and assisted lifts.